

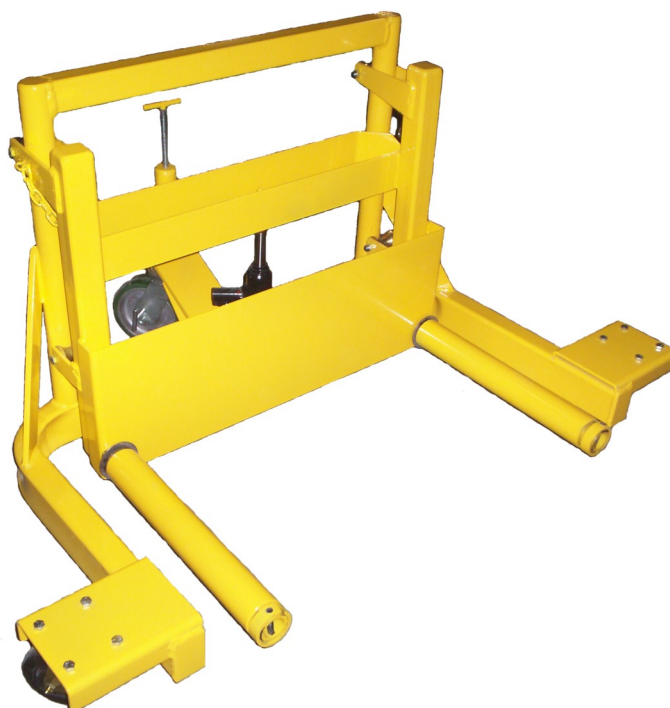

**15F590**

# Wheel & Brake Changer



**Building Quality Ground Support Products Since 1961**

- Facilitates Wheel and Brake Disc Changes
- One-man operation, reduces man-hour requirement
- Will not interfere with gear jacks
- Eliminates necessity of lifting wheels, tires, or brake disc
- Services the following jet aircraft:
  - Boeing 707, 727, 737, 747, 757, 767, 777, 787
  - Douglas DC-8, DC-9, DC-10
  - Lockheed L-1011
  - Airbus A300/310, A318-A321, A330/340, A350, A380

# CLYDE

**Clyde Machines**  
P.O. Box 194  
1150 Hwy 55 N.  
Glenwood, MN 56334 USA  
(320) 634-4504  
(320) 634-4506 Fax

[www.clydemachines.com](http://www.clydemachines.com)

# 15F590

## Wheel & Brake Changer

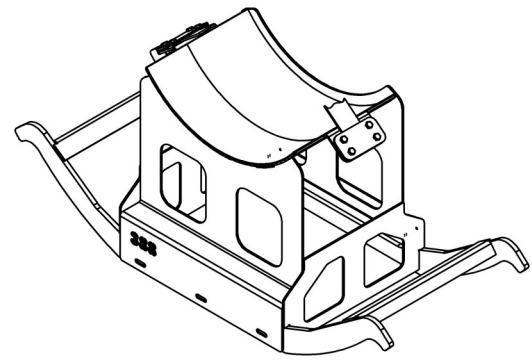
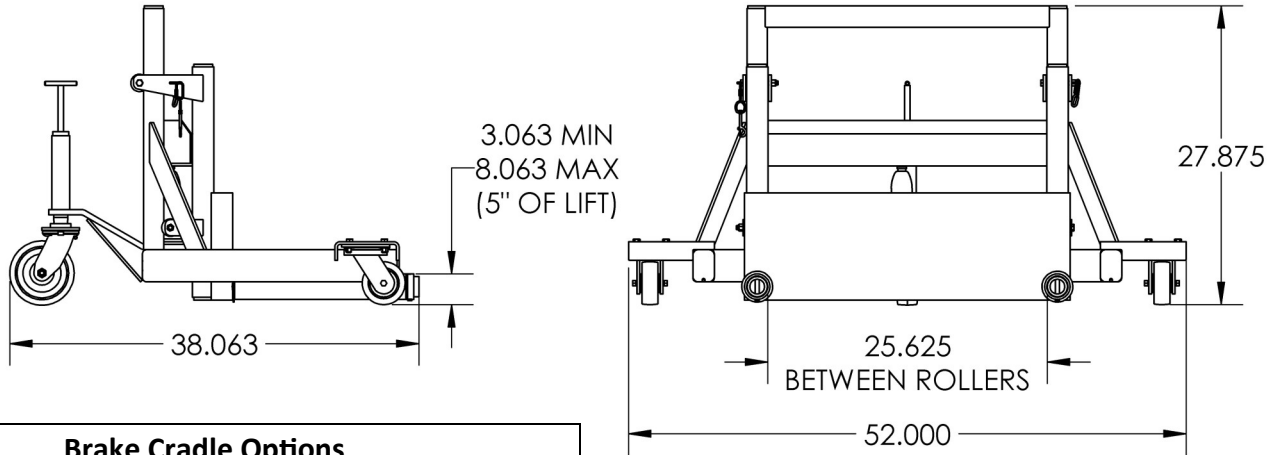

### Brake Cradle Options

| Main Gear Wheels  | Nose Gear Wheels  | Brake Cradle Model |
|---|---|--------------------|
| F70, F100   | N/A   | 15F389             |
| A300, A310, B707, B727, B757, B767                          | A300, A310, B707, B757, B767                                | 15F388             |
| A319, A320, A321, B717, B737                                | N/A   | 15F388             |
| DC8, DC9, MD80-90   | DC8   | 15F388             |
| A330, A340, A350, A380, B747, B777, B787, DC10, MD11, L1011 | A330, A340, A350, A380, B747, B777, B787, DC10, MD11, L1011 | 15F679             |

- Three Heavy Duty Casters
- Steel Rollers to support wheels, tires, or brake cradle and discs
- Hand operated screw jack to provide fore and aft tilt
- Hand operated hydraulic pump to provide vertical lift
- Durable powder coat finish
- Chain for securing wheel
- Storage box
- Max lift capacity - 750 lbs.

### Shipping Dimensions - Crated

- 58" x 39" x 34"
- 440 lbs. (370 lbs. without cradle)

### Shipping Dimensions - Pallet

- 54" x 48" x 34"
- 340 lbs. (270 lbs. without cradle)

# CLYDE

**Clyde Machines**

P.O. Box 194  
1150 Hwy 55 N.  
Glenwood, MN 56334 USA  
(320) 634-4504  
(320) 634-4506 Fax

[www.clydemachines.com](http://www.clydemachines.com)