



15F2842

B777 Towbar



Building Quality Ground Support Products Since 1961

- 8" OD x 8' High strength steel tube
- Fully retractable hydraulic running gear for adjustable height
- Safety lock system to avoid separation from aircraft
- Durable powder coat paint
- Quality shear bolts for aircraft protection
- Extra set of shear bolts included
- Solid tires

- Options:
 - Pneumatic tires
 - Cushioned lunette assembly

CLYDE

Clyde Machines
P.O. Box 194
1150 Hwy 55 N.
Glenwood, MN 56334 USA
(320) 634-4504
(320) 634-4506 Fax

www.clydemachines.com

15F2842

B777 Towbar

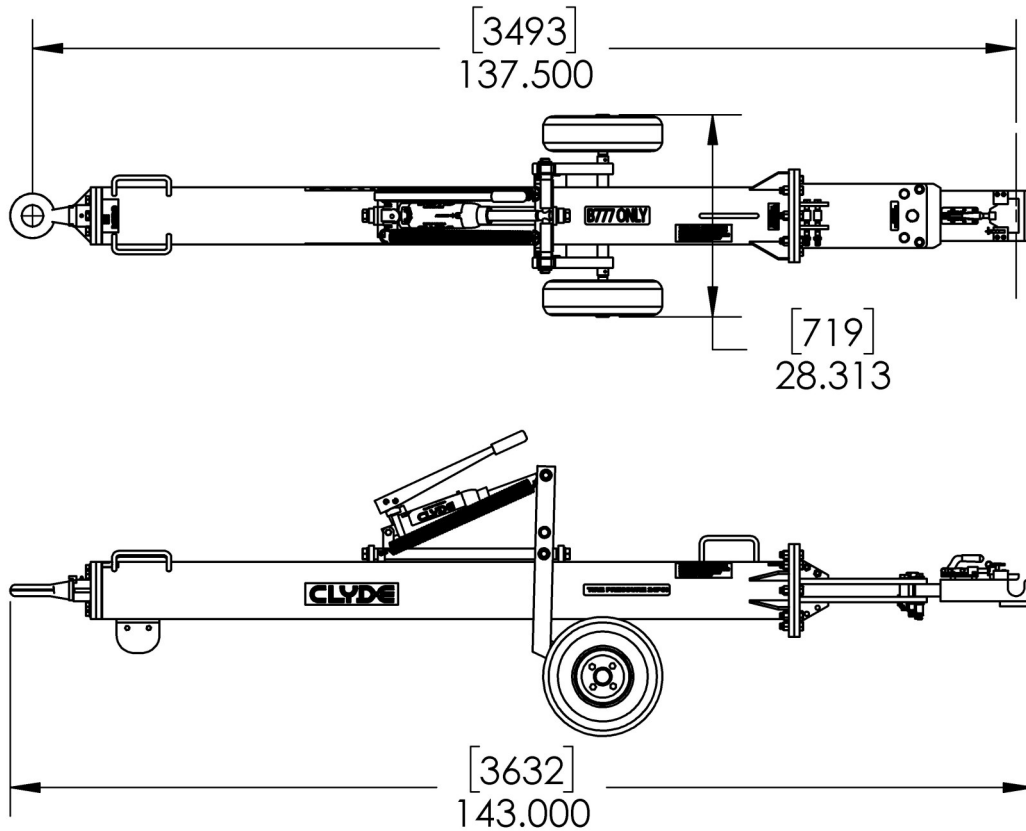

Shipping Information

- Shipping Dimensions:
 - Weight — 630 lbs.
 - Length — 143"
 - Width — 29"
 - Height — 25"
- Crated Dimensions:
 - Weight — 980 lbs.
 - Length — 152"
 - Width — 26"
 - Height — 36"

CLYDE

Clyde Machines
P.O. Box 194
1150 Hwy 55 N.
Glenwood, MN 56334 USA
(320) 634-4504
(320) 634-4506 Fax

www.clydemachines.com