

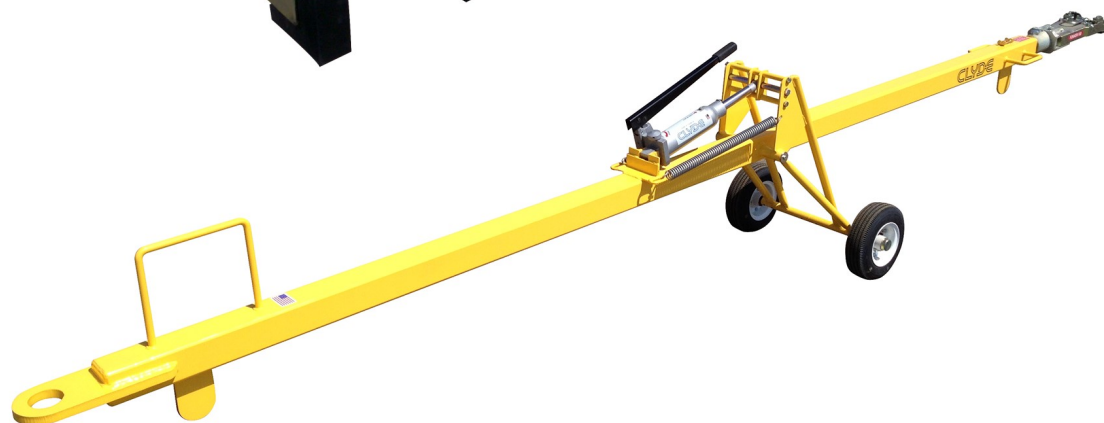

15F2532

F100/F70 Towbar

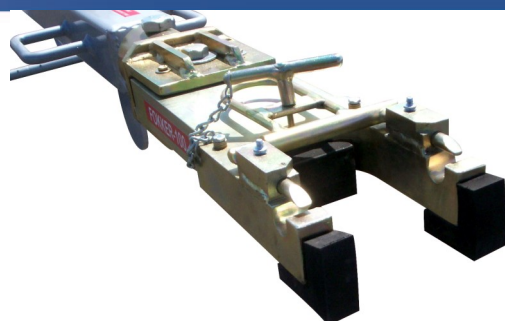

Building Quality Ground Support Products Since 1961

- Main frame constructed of structural tube
- Fully retractable hydraulic running gear for adjustable height
- Safety lock system to avoid separation from aircraft
- Steel supports on both ends protect head and body from hitting the ground
- Durable powder coat finish
- Quality shear bolts for aircraft protection
- Extra set of shear bolts included
- Solid tires
- Optional pneumatic tires

CLYDE

Clyde Machines
P.O. Box 194
1150 Hwy 55 N.
Glenwood, MN 56334 USA
(320) 634-4504
(320) 634-4506 Fax

www.clydemachines.com

15F2532

F100/F70 Towbar

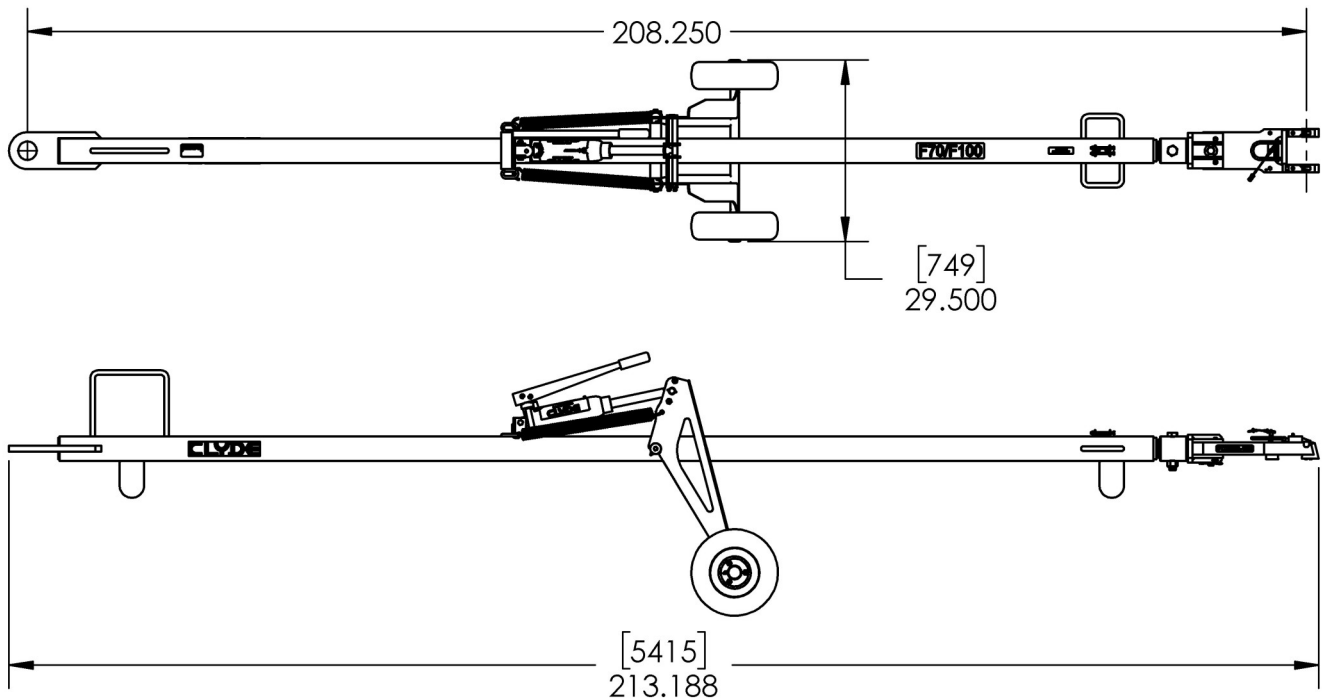

Shipping Information

- Shipping Dimensions:
 - Weight — 410 lbs.
 - Length — 214"
 - Width — 30"
 - Height — 25"
- Crated Dimensions:
 - Weight — 775 lbs.
 - Length — 217"
 - Width — 26"
 - Height — 28"

CLYDE

Clyde Machines
P.O. Box 194
1150 Hwy 55 N.
Glenwood, MN 56334 USA
(320) 634-4504
(320) 634-4506 Fax

www.clydemachines.com