



15F3150

Elec. Mobile Passenger Stair



Building Quality Ground Support Products Since 1961

- Operation Height: 88" - 161"
- Upper Platform size: 88" x 63"
- Step width: 48"
- Galvanized steps and platform
- Swivel platform bumper adjusts +/- 5 deg.
- Modesty panels on all steps and platform handrails
- LED lighting system with adjustable timer
- LED headlights, taillight, turn signals
- Hydraulic power steering
- Dual hydraulic braking
Lever actuated parking brake
- 80 volt battery
- 110V onboard battery charger and quick charge receptacle
- Battery level indicator
- Four hydraulic stabilizer jacks
- Curtis 1238 controller
- Horn
- Back up alarm
- 225, 75 x 16 Tires
- Front solid, rear 6 leaf spring suspension
- Sevcon converter
- Fore and aft tow rings
- Speed limitation mode when stairs are raised for safety
- Hydraulic oil level indicator
- Dead man switch for seat

CLYDE

Clyde Machines
P.O. Box 194
1150 Hwy 55 N.
Glenwood, MN 56334 USA
(320) 634-4504
(320) 634-4506 Fax

www.clydemachines.com

15F3150

Elec. Mobile Passenger Stair

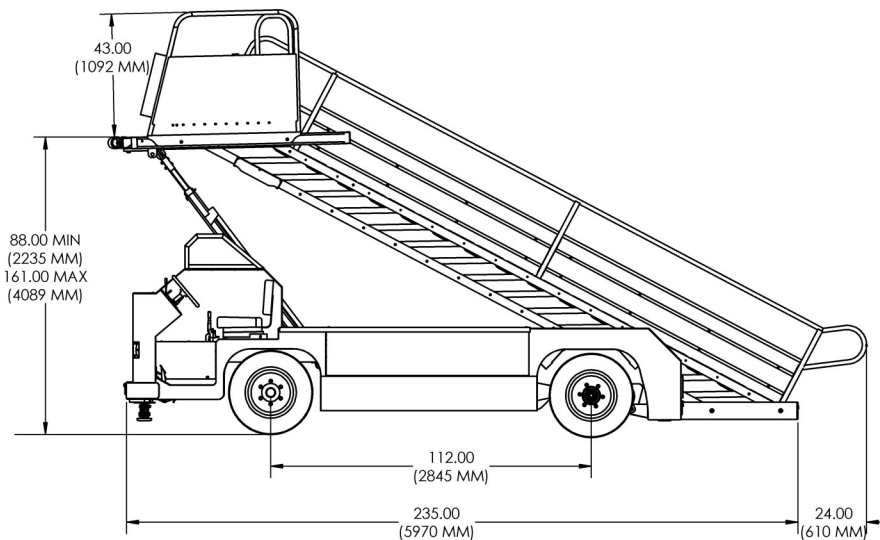
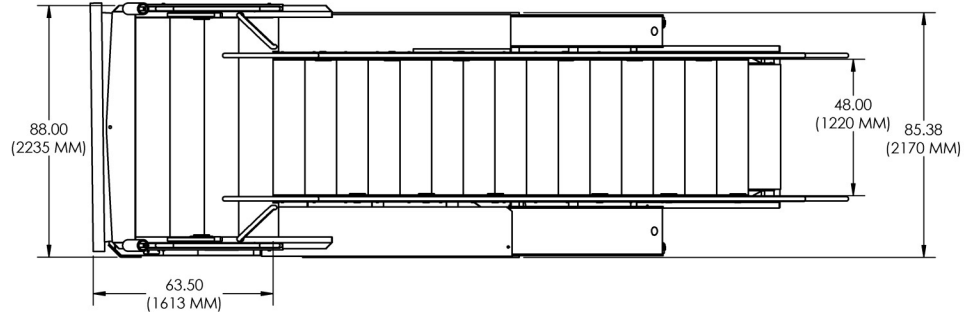

- Services various passenger door sill heights, 88" to 161"
- Platform capacity, 1,000 lbs. / Full stairway capacity, 3,500 lbs.
- Sliding handrails to clear aircraft door
- 4" O.D. Non-marring soft rubber bumpers
- Durable powder coat finish
- Dimensions:
 - Weight - 9820 lbs.
 - Length - 277"
 - Width - 89"
 - Height - 116"

CLYDE

Clyde Machines
P.O. Box 194
1150 Hwy 55 N.
Glenwood, MN 56334 USA
(320) 634-4504
(320) 634-4506 Fax

www.clydemachines.com