



15F3281

Access Stand



Building Quality Ground Support Products Since 1961

- 80" high to the top step
- Swivel castor with brakes
- Single lever stabilizer/brake
- Bumpers to protect aircraft
- Durable powder coat finish
- Meets OSHA specifications

CLYDE

Clyde Machines
P.O. Box 194
1150 Hwy 55 N.
Glenwood, MN 56334 USA
(320) 634-4504
(320) 634-4506 Fax

www.clydemachines.com

15F3281

Access Stand

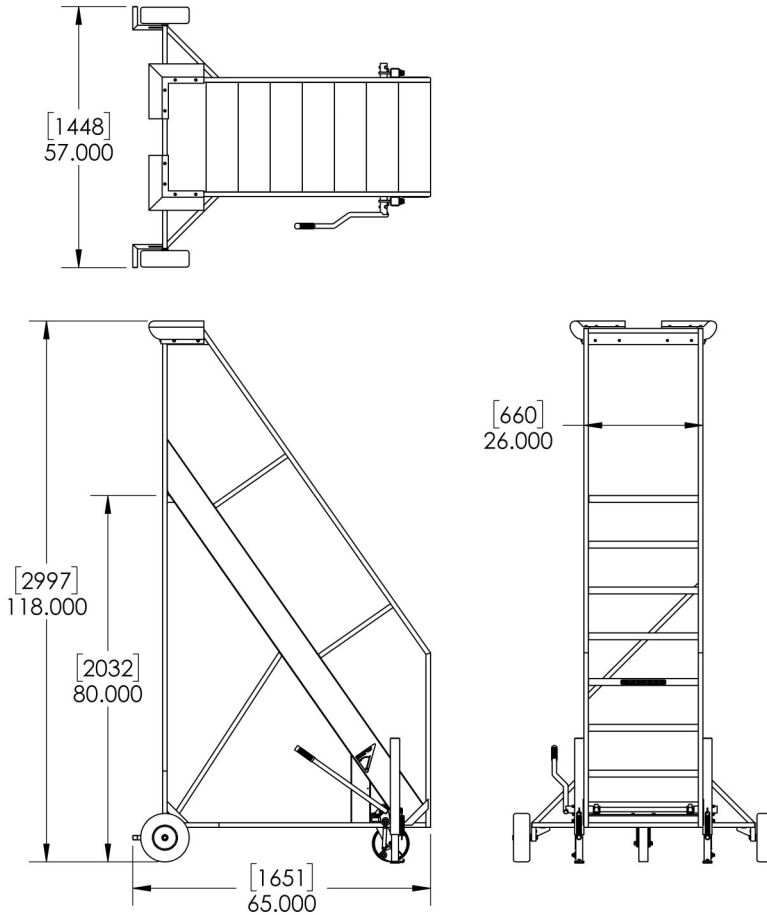

Shipping Information

- Dimensions:
 - Weight - 275 lbs.
 - Length - 65"
 - Width - 57"
 - Height - 118"

CLYDE

Clyde Machines
P.O. Box 194
1150 Hwy 55 N.
Glenwood, MN 56334 USA
(320) 634-4504
(320) 634-4506 Fax

www.clydemachines.com