



15F1900

# Crew Stair Config.



- Shown with:
  - 15F2943 4x6 Platform
  - 15F2496 Large Caster option
  - 15F2646 Air/Hyd. Pump Assy.
  - 15F3112 Strut Kit

## Building Quality Ground Support Products Since 1961

- 500 lb. platform capacity
- Adjustable to any height within its 3' to 12' platform floor range
- Double acting hydraulic hand pump
- Hydraulic restrictors in case of pressure failure
- Non-slip self-cleaning steps and platform floor
- Heavy-duty casters and 16" dia. pneumatic tires
- Hand adjustable screw jacks for stability
- Stair and platform railings can be lifted out and stored on the base
- Base, stairs, and platform stay parallel at any height position
- Durable powder coat finish
- 4.00 x 8 solid tires

# CLYDE

Clyde Machines  
P.O. Box 194  
1150 Hwy 55 N.  
Glenwood, MN 56334 USA  
(320) 634-4504  
(320) 634-4506 Fax

[www.clydemachines.com](http://www.clydemachines.com)

# 15F1900

## Crew Stair Config.

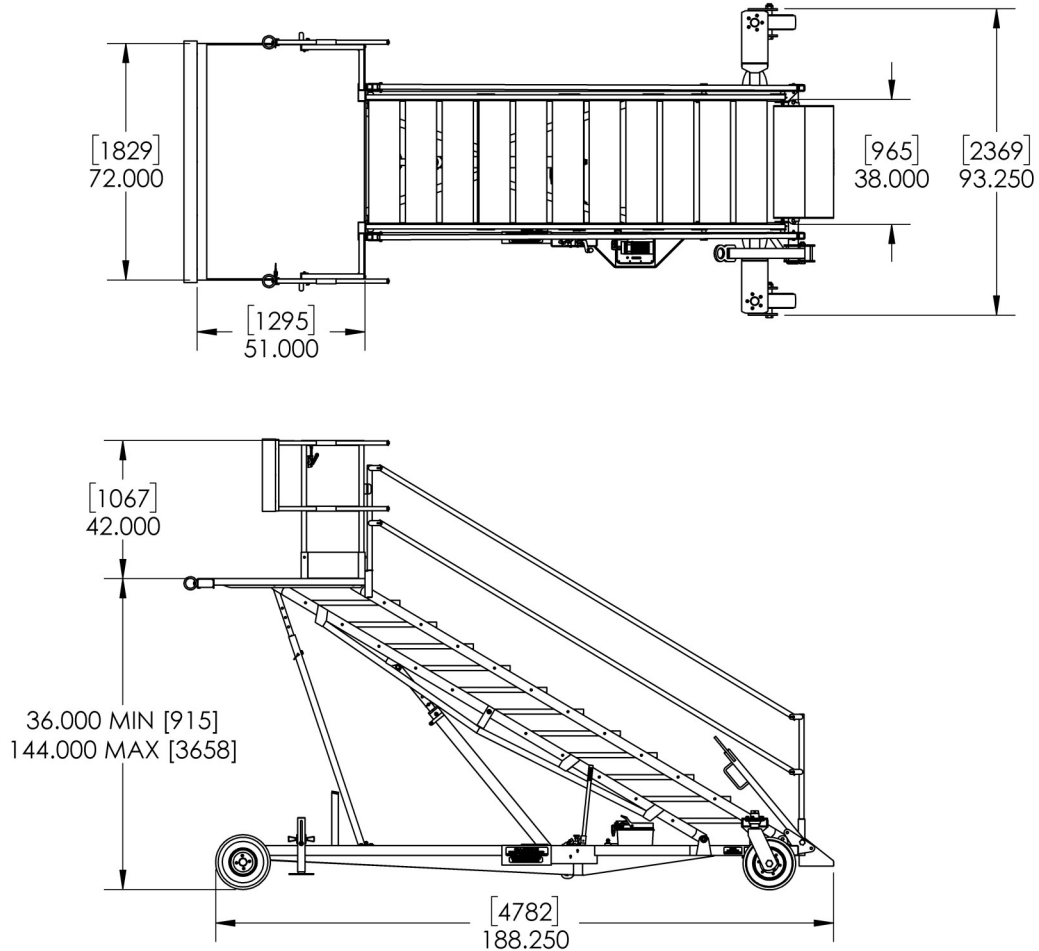

### Shipping Information

- Dimensions:
  - Weight - 2178 lbs.
  - Length - 240"
  - Width - 94"
  - Height - 48"

# CLYDE

**Clyde Machines**  
P.O. Box 194  
1150 Hwy 55 N.  
Glenwood, MN 56334 USA  
(320) 634-4504  
(320) 634-4506 Fax

[www.clydemachines.com](http://www.clydemachines.com)