



15F3500 with Option

Baggage Cart



Building Quality Ground Support Products Since 1961

- 5' x 10' open cart
- 8,000 lb. capacity with Standard Solid Tires
- Pneumatic tire option, reduces capacity to 4,000 lbs.
- Fifth wheel steering with towbar actuated parking brake
- E-type rear hitch
- Removable end panels
- V - floor
- Max tow speed 20 mph (32 kph)
- Durable powder coat finish
- 15F3212 storable tarp option
- 15F3324 fold down side panels

CLYDE

Clyde Machines
P.O. Box 194
1150 Hwy 55 N.
Glenwood, MN 56334 USA
(320) 634-4504
(320) 634-4506 Fax

www.clydemachines.com

15F3500

Baggage Cart

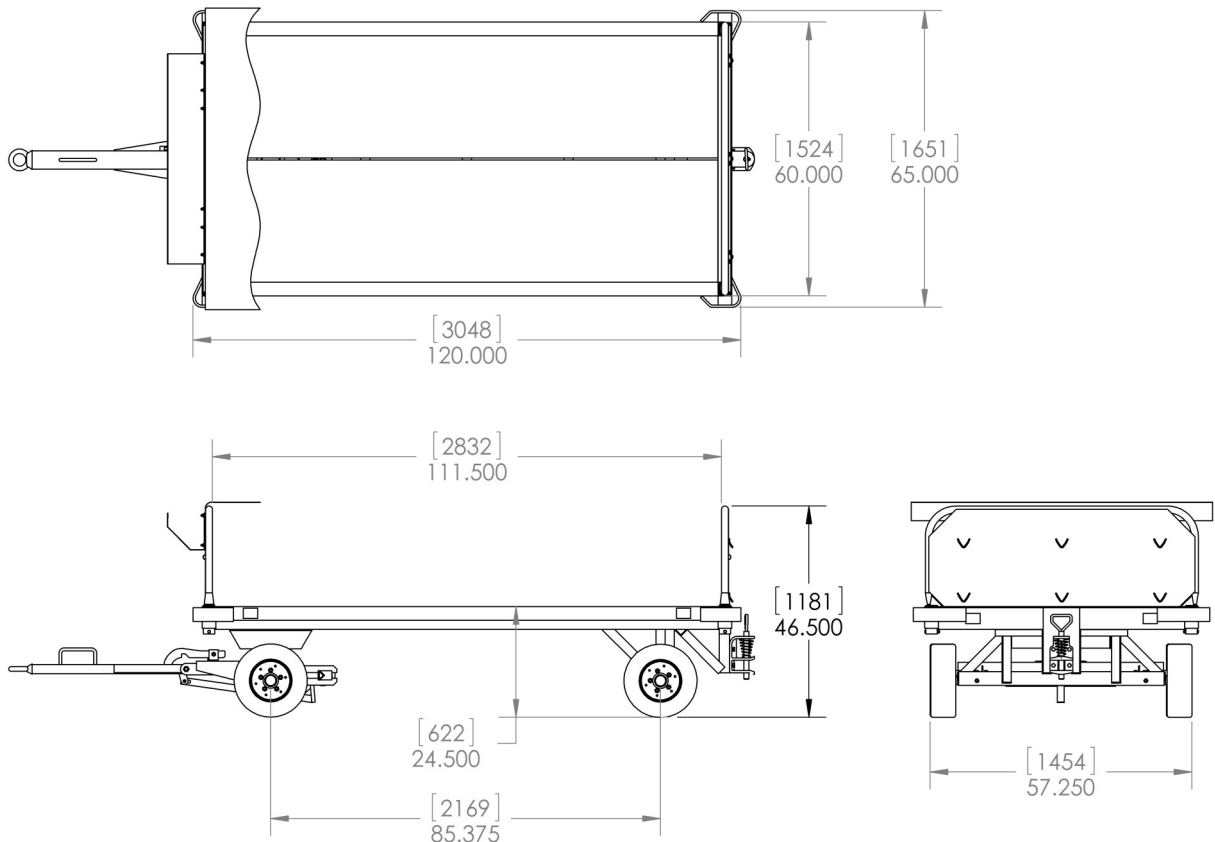

Shipping Information

- Dimensions:
 - Weight - 1025 lbs.
 - Length - 144" (Towbar up)
 - Length - 164" (Towbar down)
 - Width - 65"
 - Height - 24 1/2" (w/o side panels)
 - Height - 46 1/2" (w/ side panels)

CLYDE

Clyde Machines
P.O. Box 194
1150 Hwy 55 N.
Glenwood, MN 56334 USA
(320) 634-4504
(320) 634-4506 Fax

www.clydemachines.com